

# **Protocolos de Acesso ao Meio**

**Profa. Débora Christina Muchaluat Saade**

**debora@midiacom.uff.br**

# Tipos de Protocolos

⇒ **Protocolos de Acesso Baseados em Contenção**

⇒ **Protocolos de Acesso Ordenado sem Contenção**

# **Protocolos de Acesso baseados em Contenção**

# Protocolos de Acesso Baseados em Contenção

⇒ **Retardo de transferência não limitado**

⇒ **Ausência de equidade**

⇒ **Instabilidade em sobrecarga**

# Protocolos de Acesso Baseados em Contenção

*Redes de Computadores II*

- ⇒ **Aloha**
- ⇒ **Slotted-Aloha**
- ⇒ **CSMA**
- ⇒ **CSMA-CD**
- ⇒ **CSMA-CA**

# Aloha

# Aloha

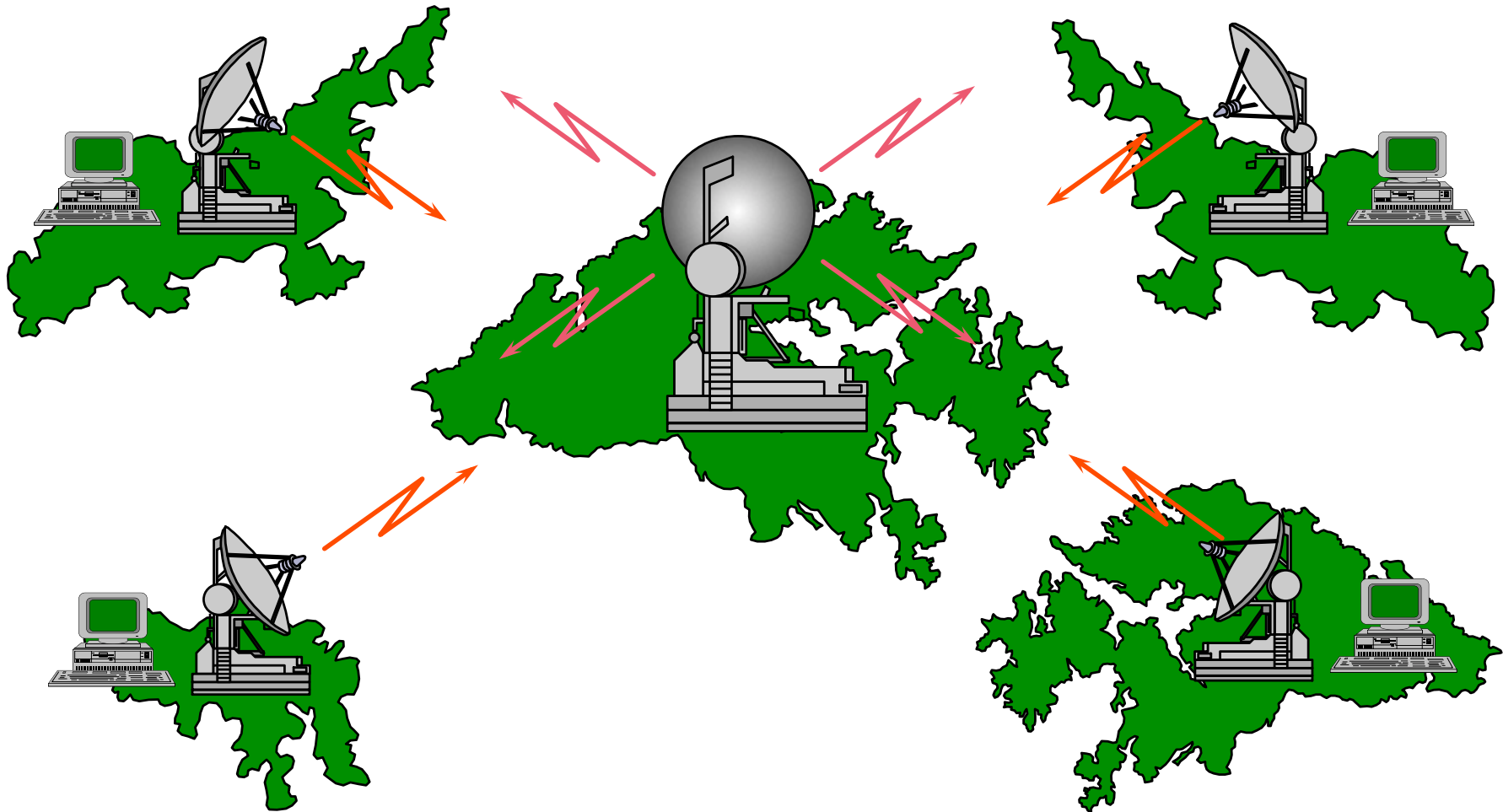

# Aloha

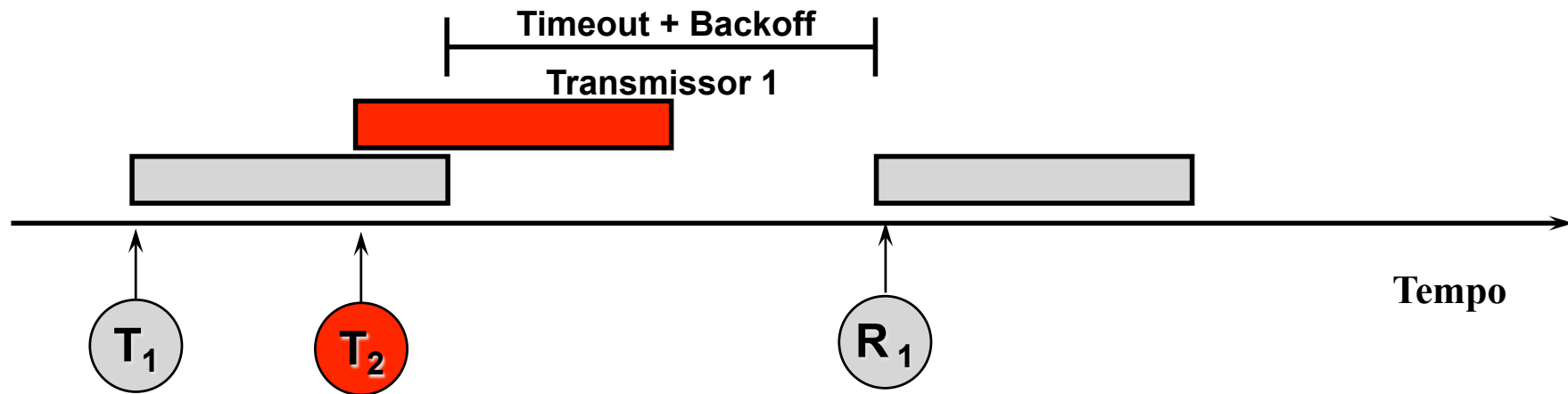



# Aloha

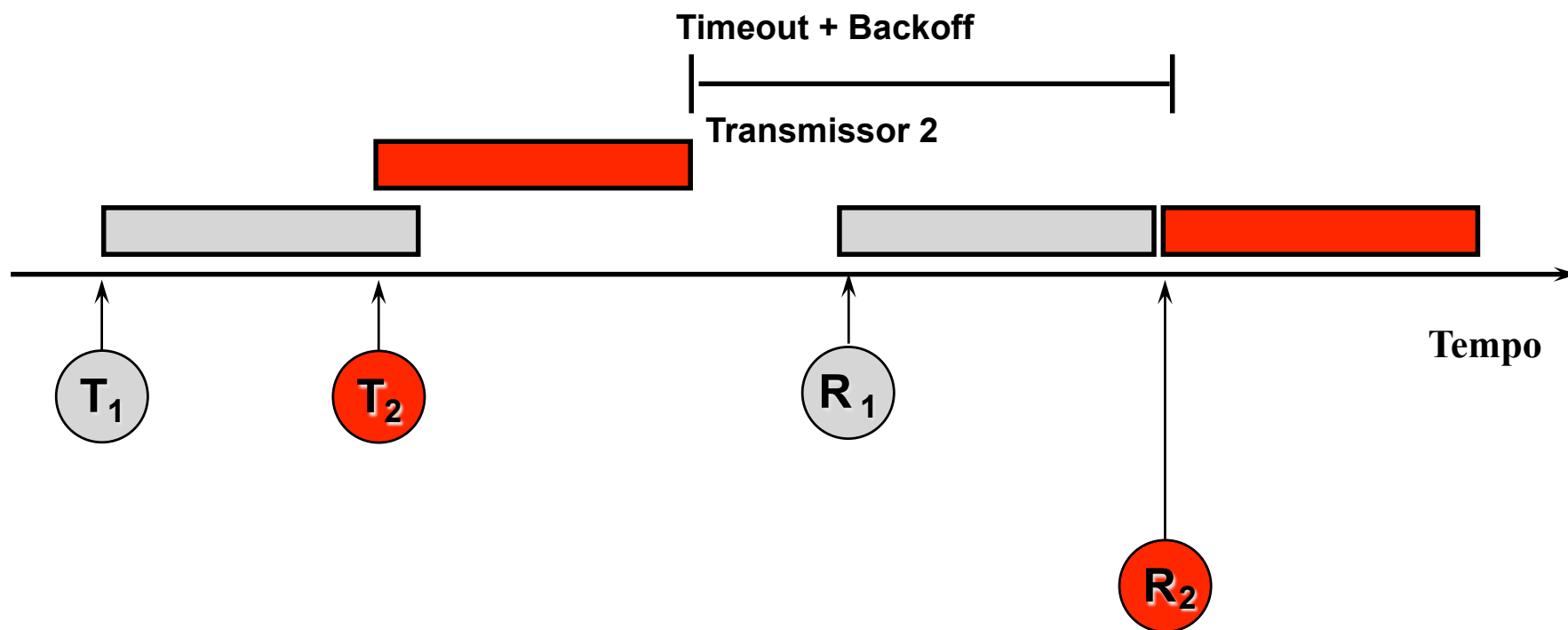

# Aloha

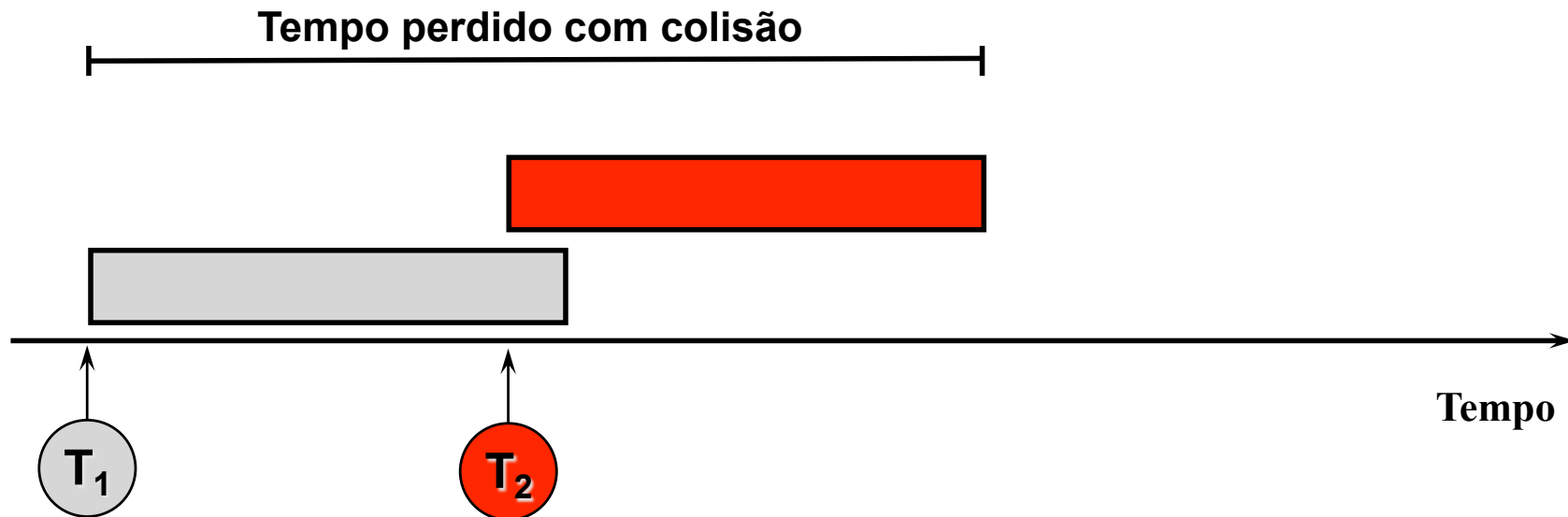

# Aloha

**Menor tempo perdido com colisão**

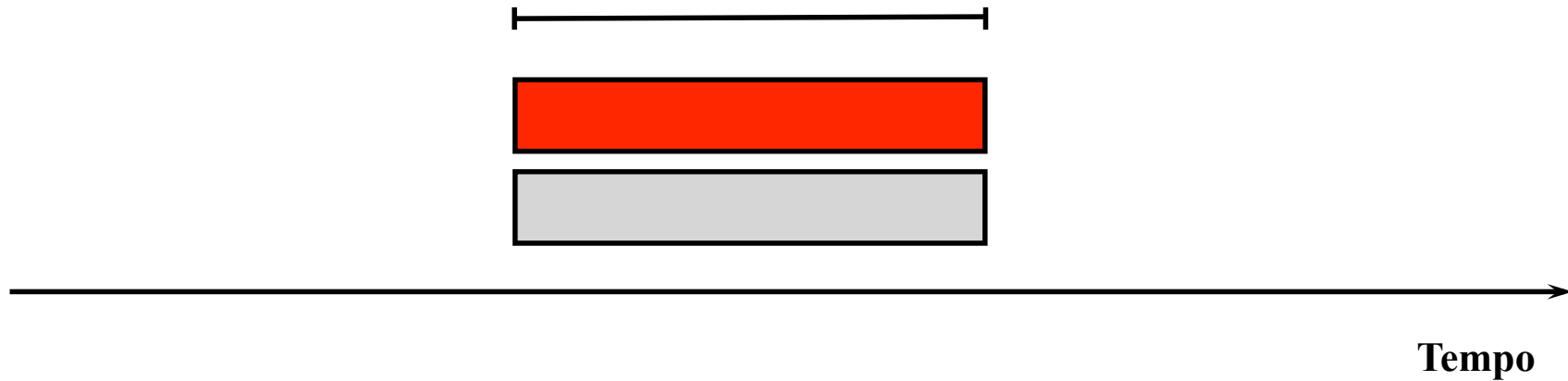

# Slotted Aloha

# Slotted Aloha

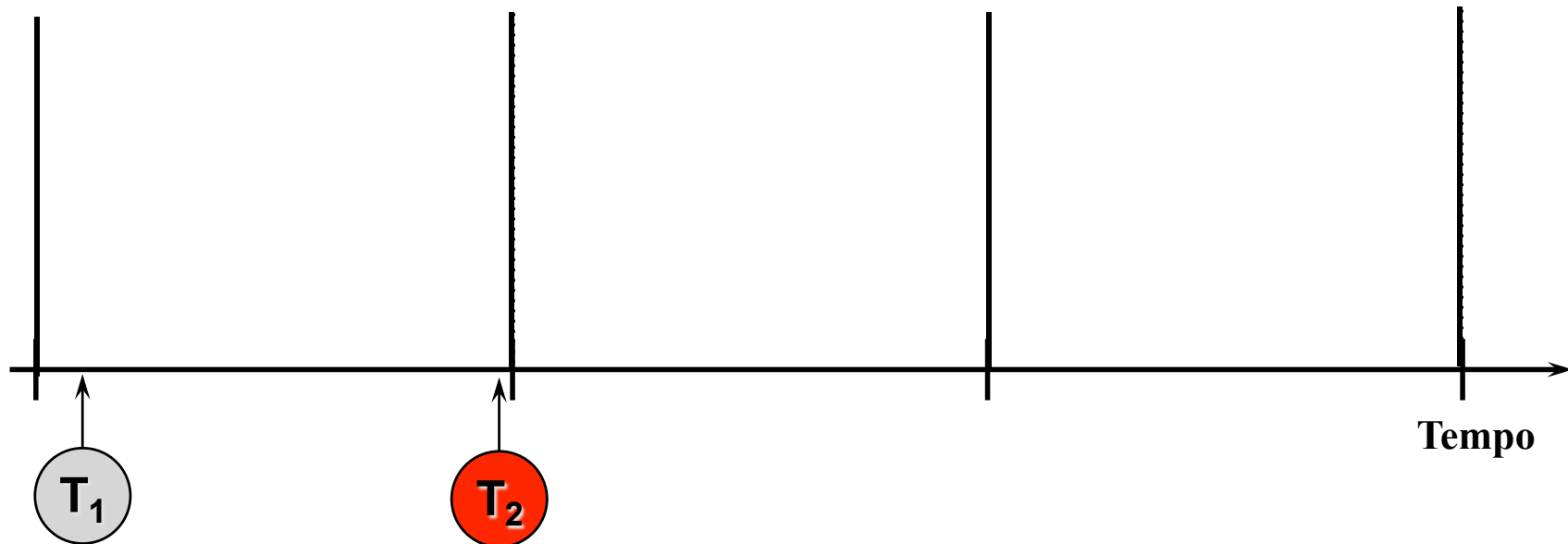

# Slotted Aloha

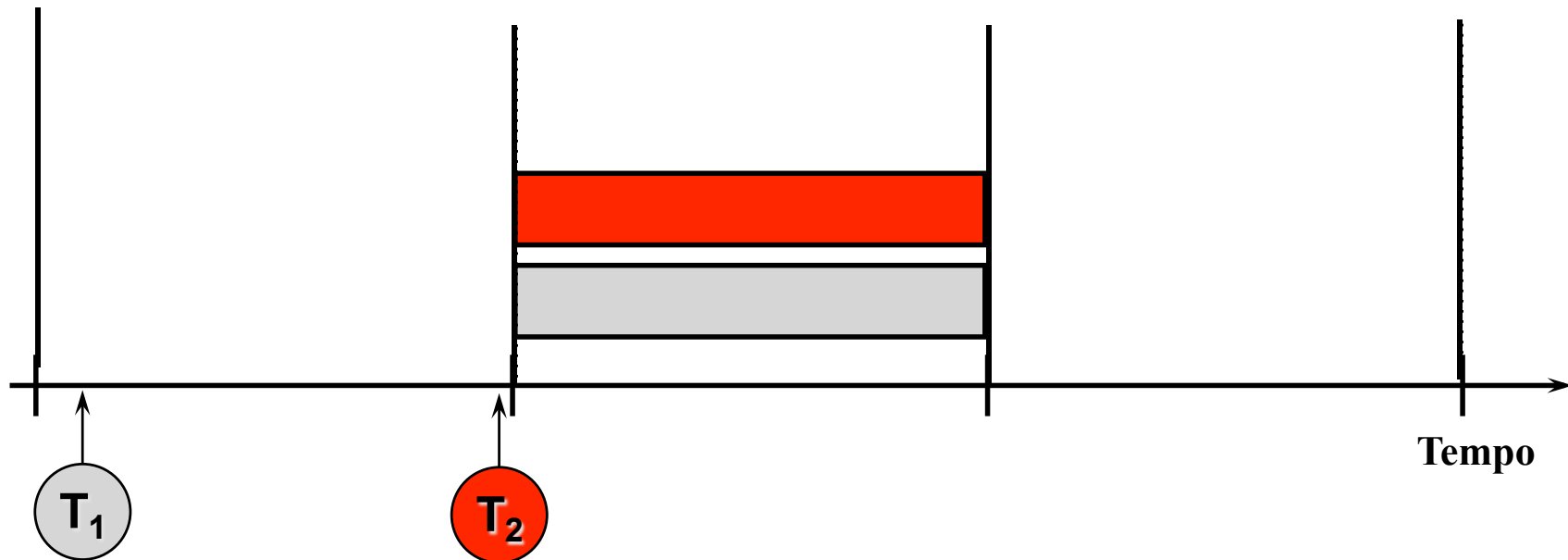

# Slotted Aloha

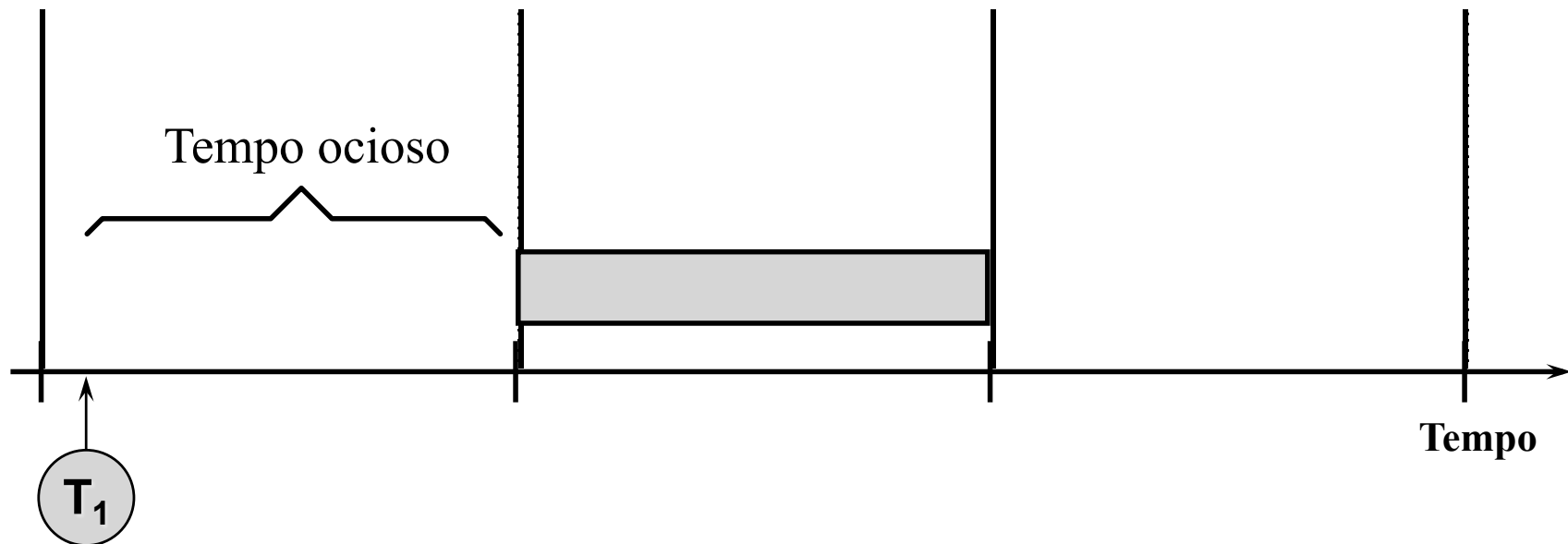

# Aloha X Slotted-Aloha

**Aloha**

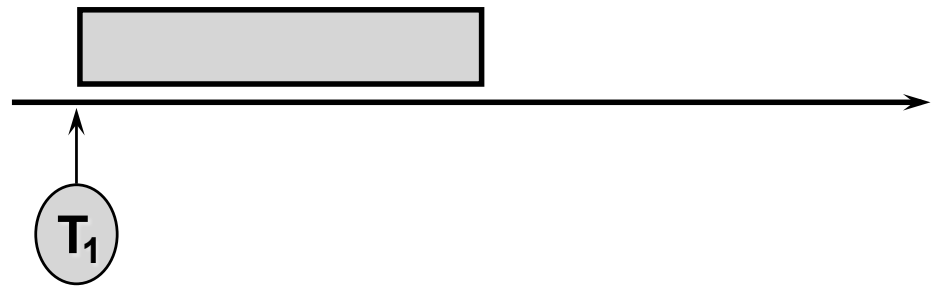
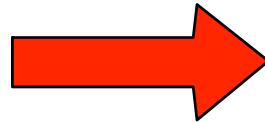

**Slotted-Aloha**

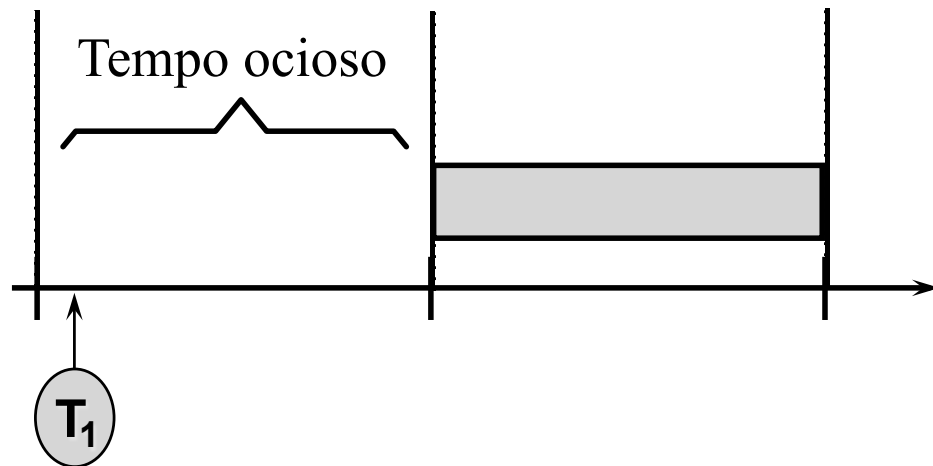
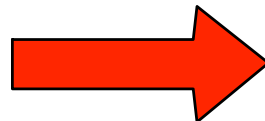



# Aloha X Slotted-Aloha

**Aloha**

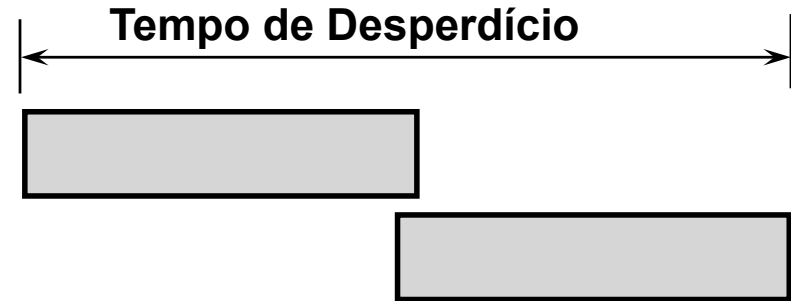
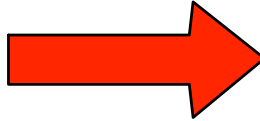

**Slotted-Aloha**

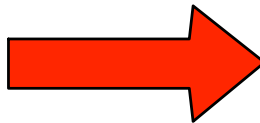

Tempo de Desperdício

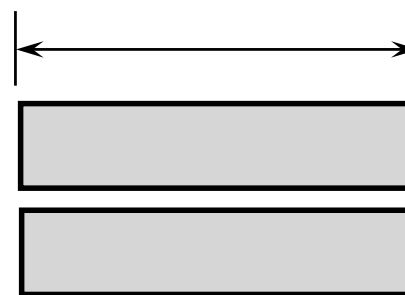

# Aloha

## ⇒ Eficiência

- *Aloha 18%*
- *Slotted Aloha 37%*

⇒ Não tem equidade

⇒ Não tem prioridade

⇒ Retardo de transferência aleatório

⇒ Instabilidade em sobrecarga

# CSMA

## **Carrier Sense Multiple Access**

# CSMA (Carrier Sense Multiple Access)

*Redes de Computadores II*

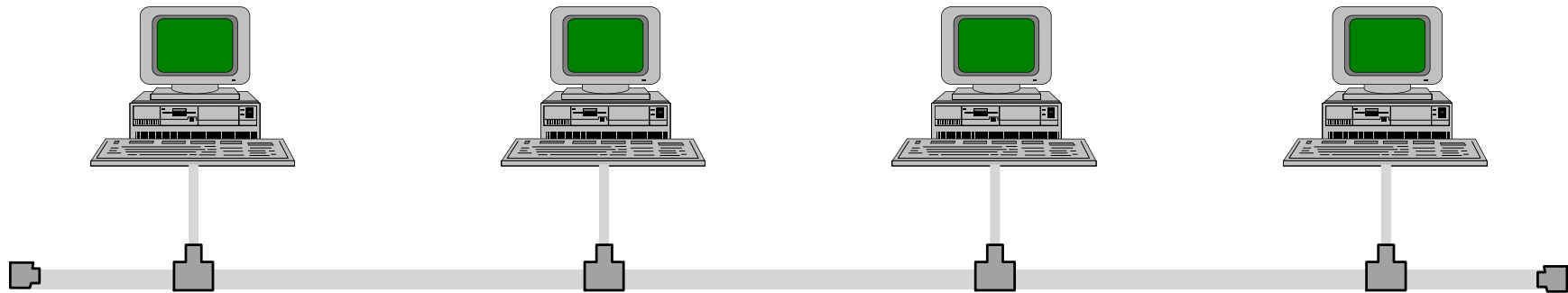

# CSMA



# CSMA



# CSMA



# CSMA

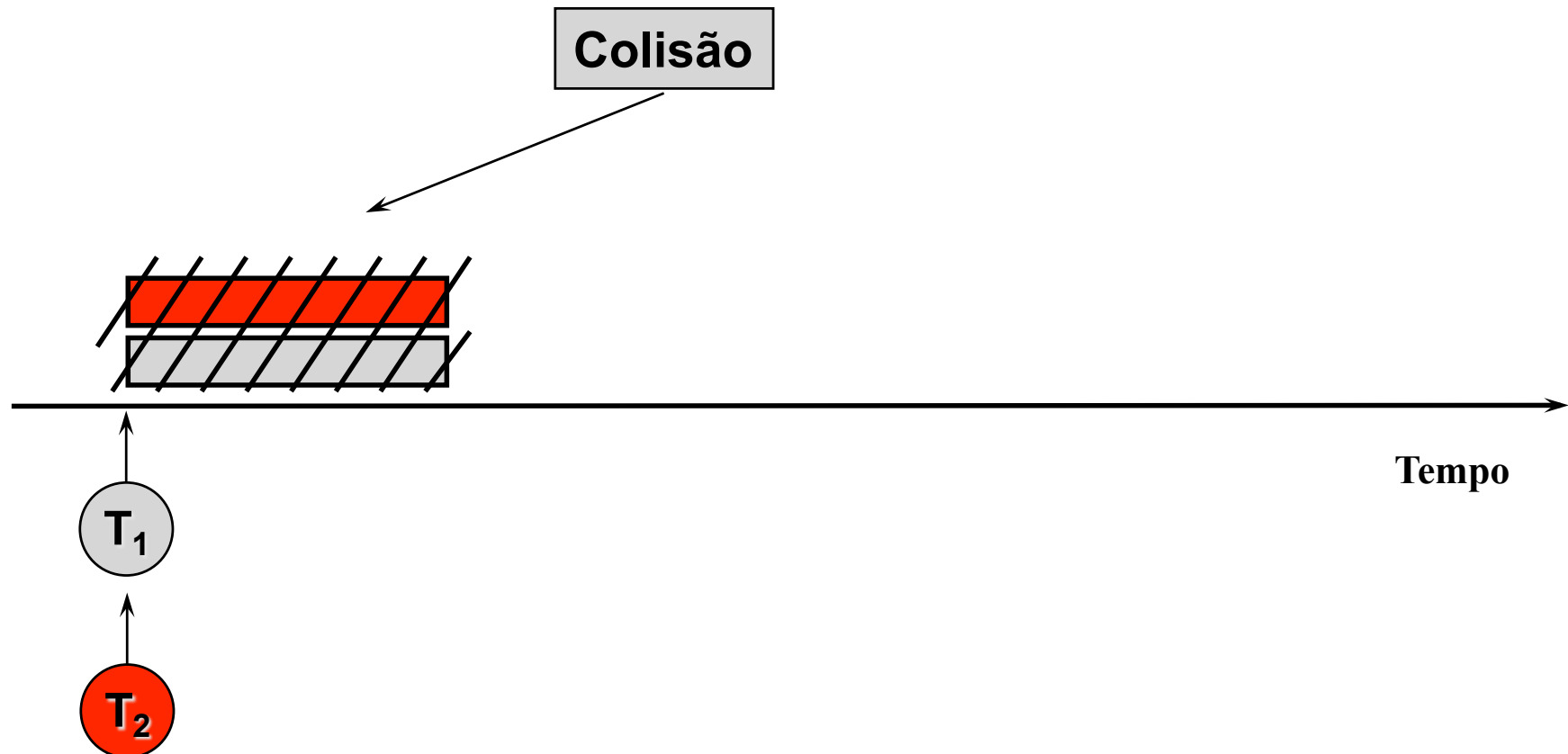



# CSMA

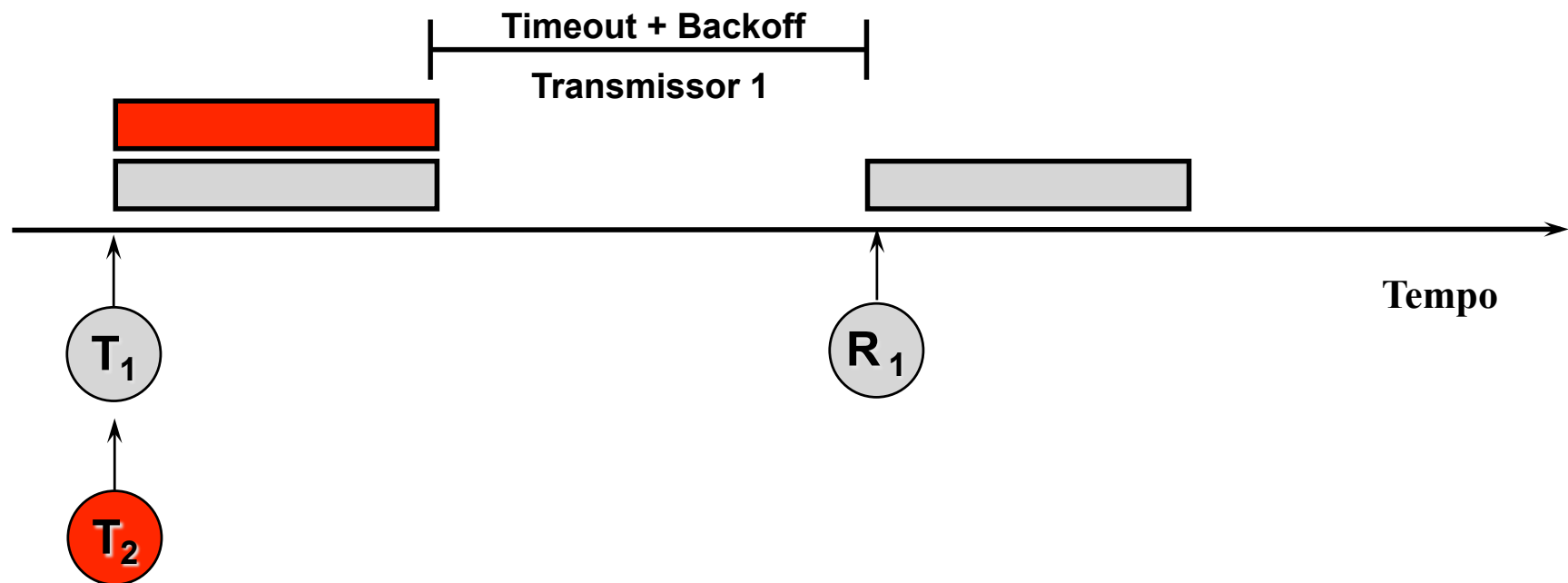

# CSMA

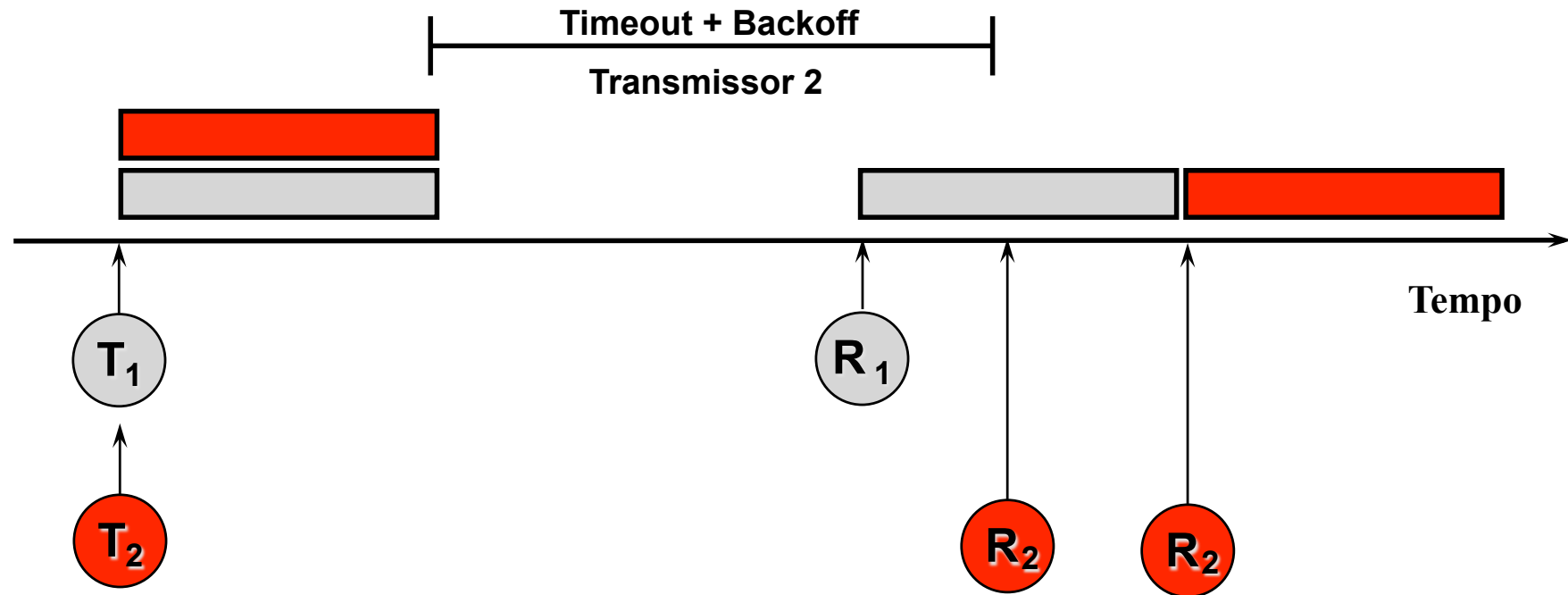

# CSMA 1-Persistente

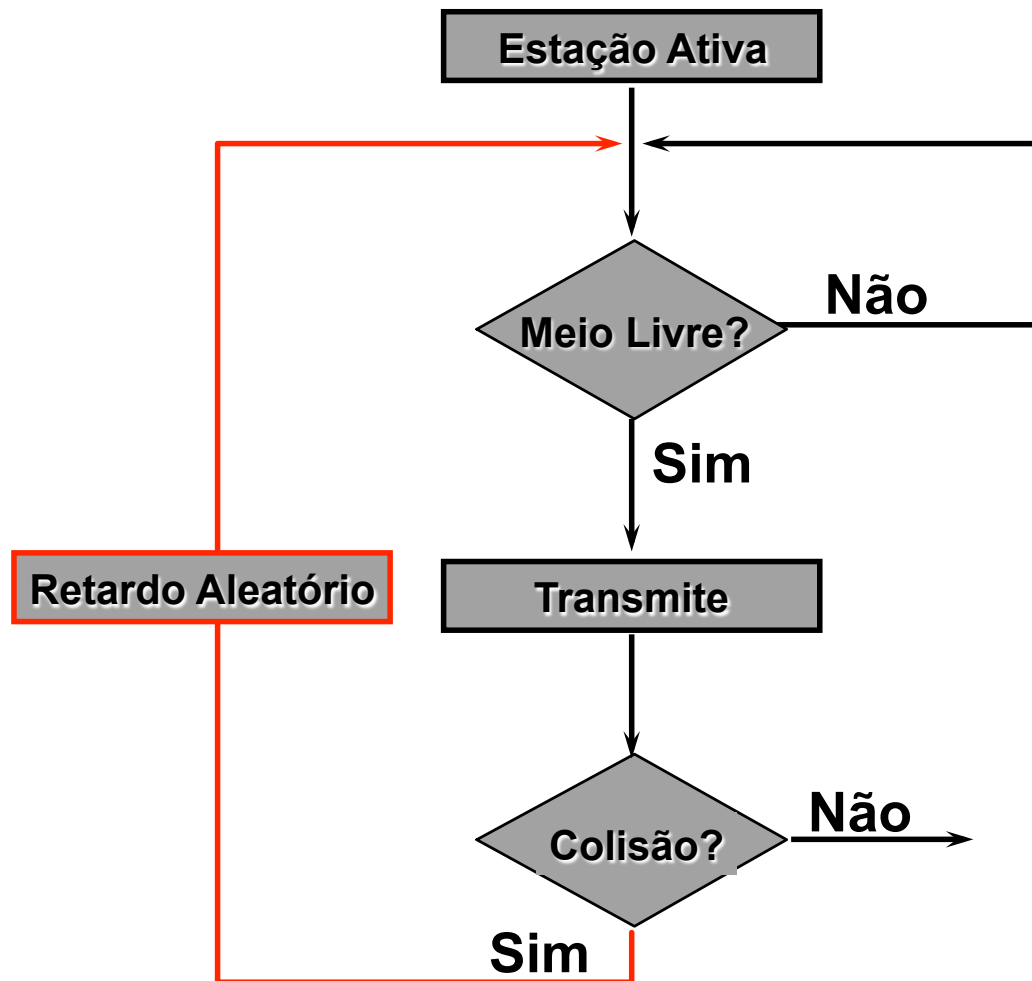

# Técnica CSMA Não Persistente

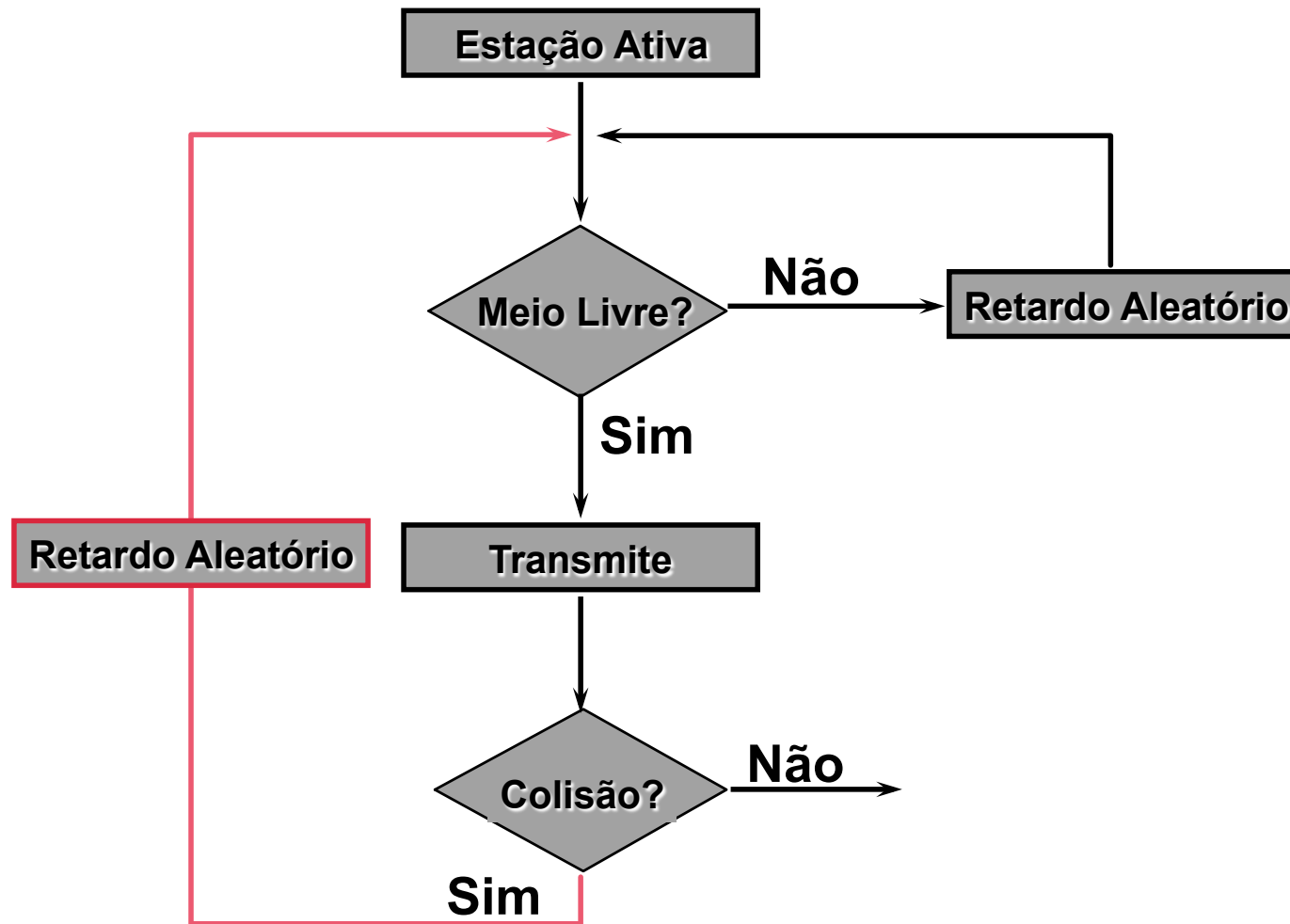

# CSMA-NP

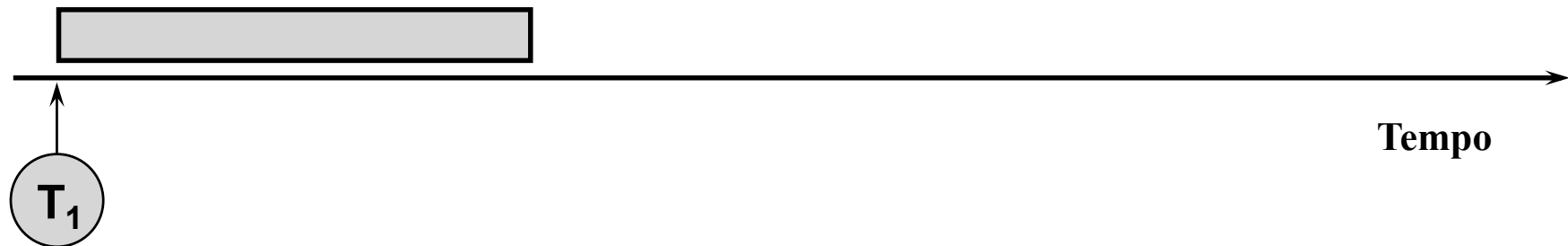

# CSMA-NP

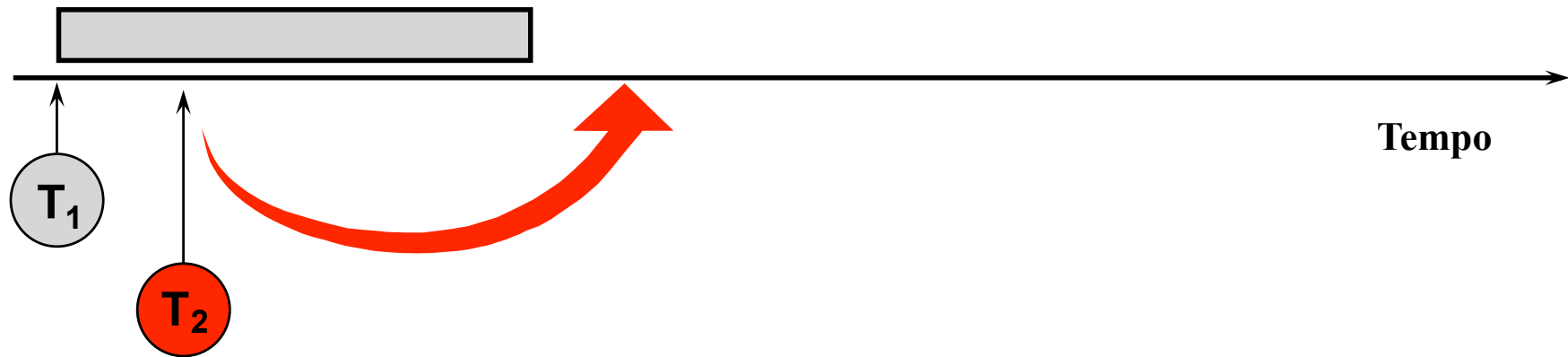

# CSMA-NP

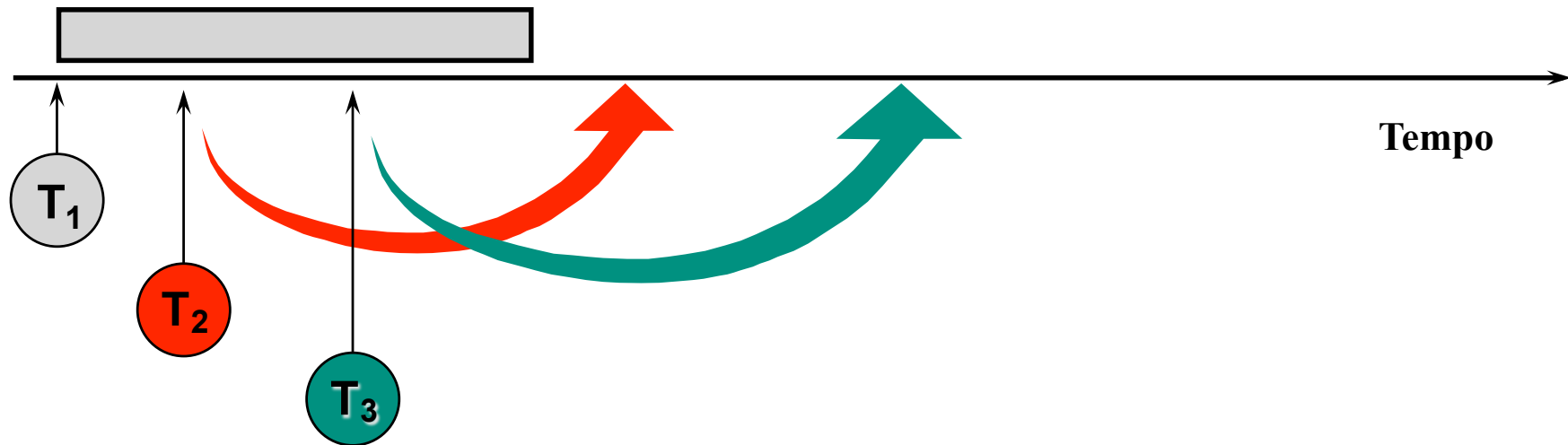

# CSMA-NP

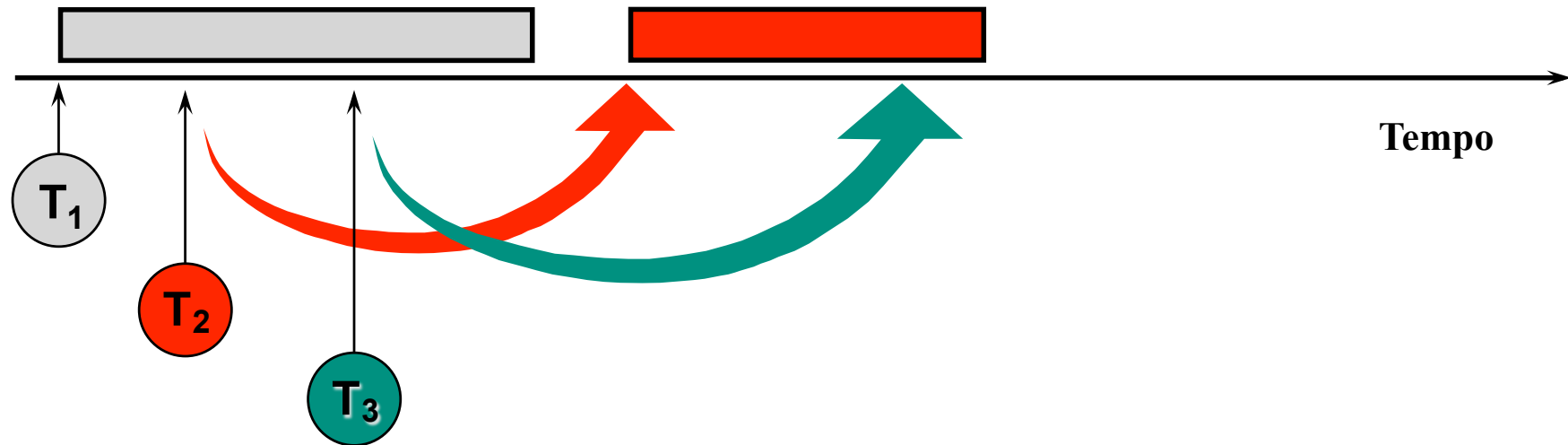



# CSMA-NP

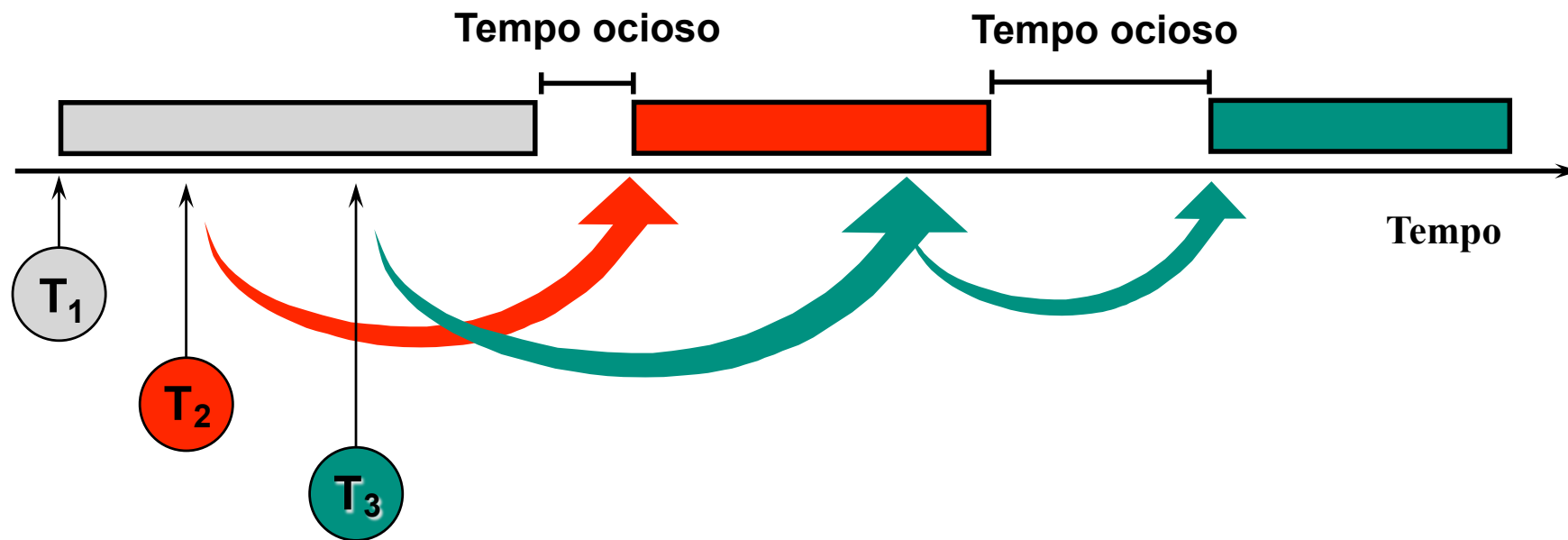

# CSMA/CD

## **Carrier Sense Multiple Access with Collision Detection**

# CSMA/CD

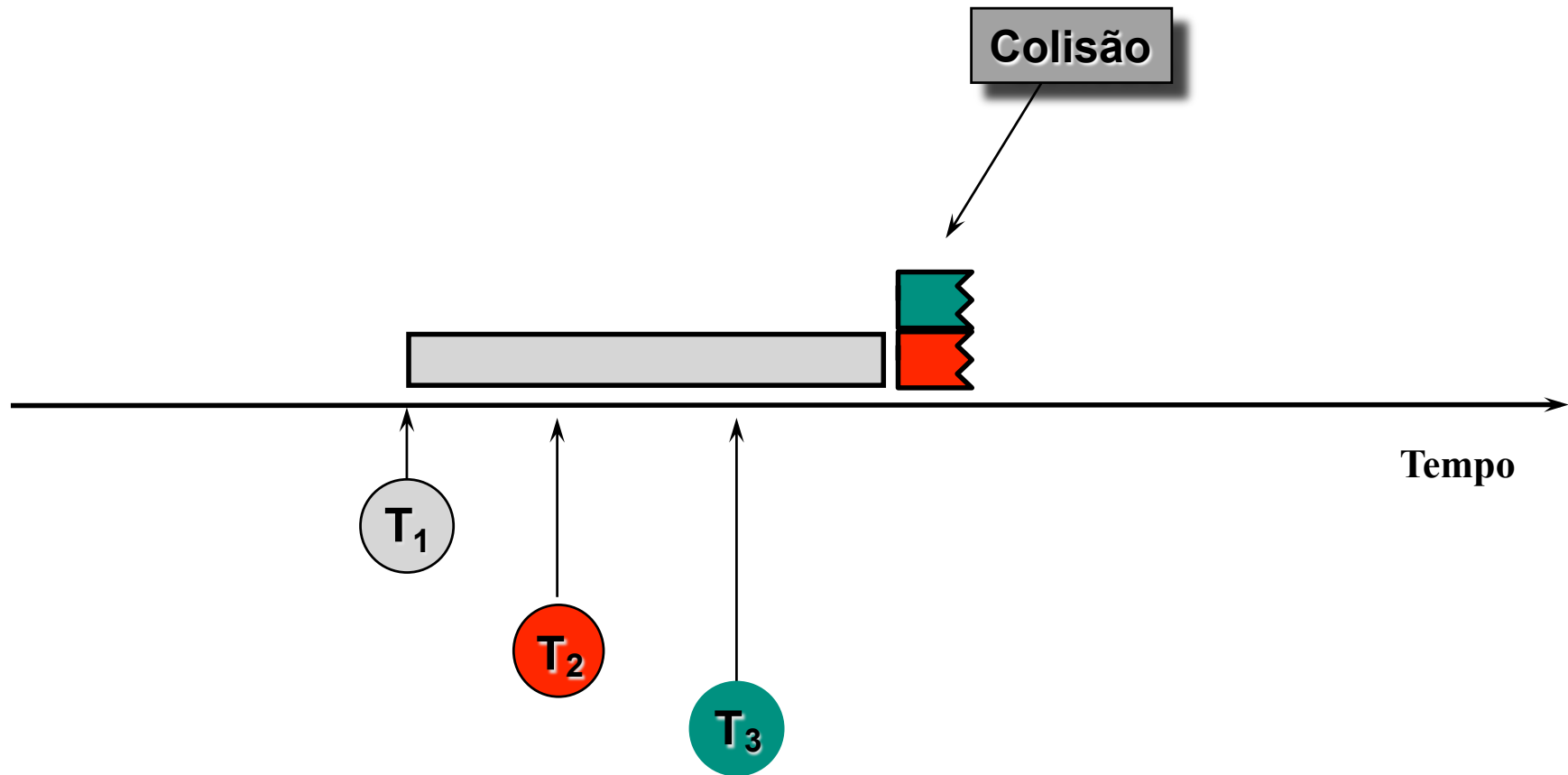

# Técnica CSMA/CD

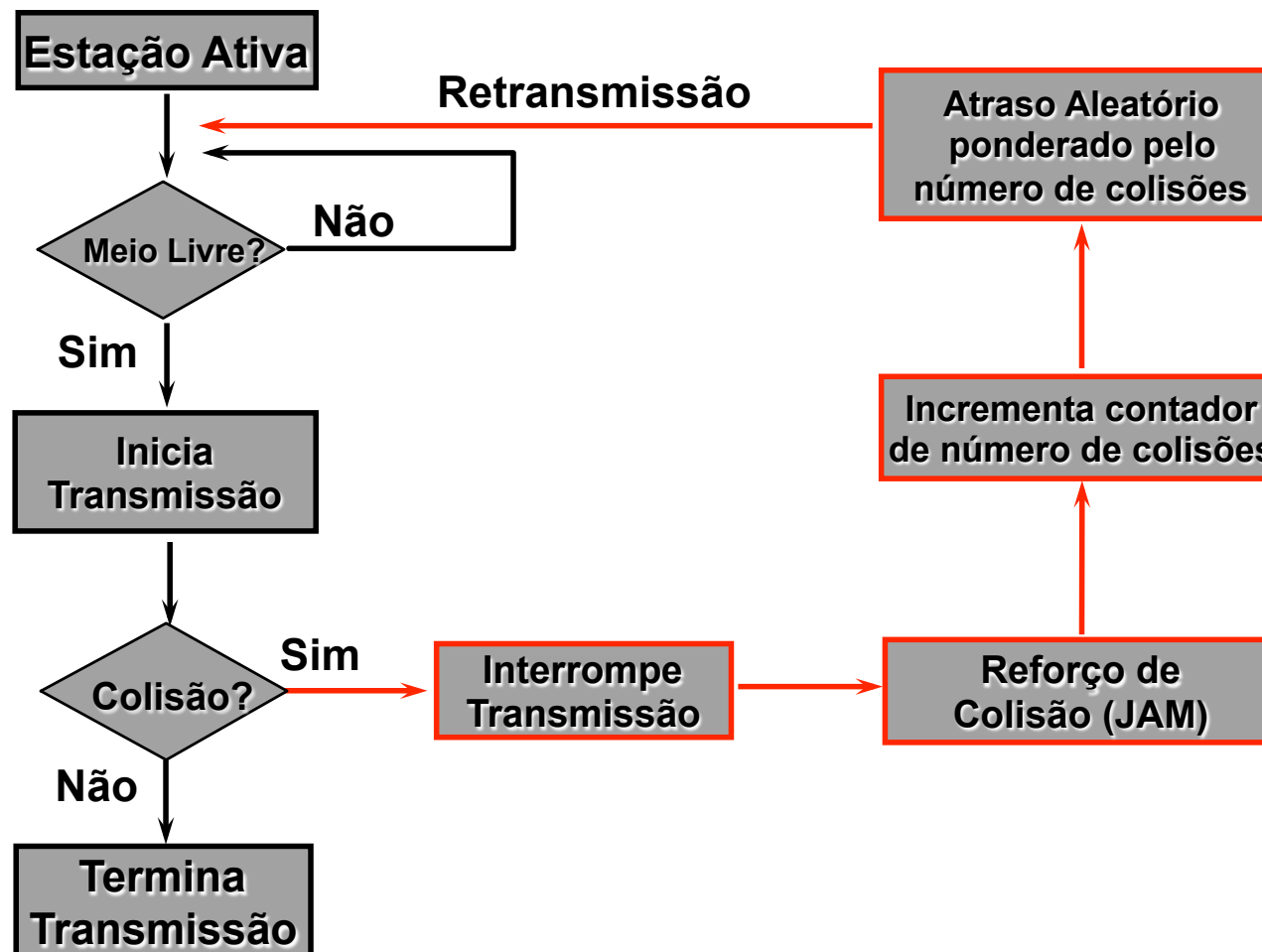

## ⇒ Espera Aleatória Exponencial Truncada

- *se houve colisão, espera tempo aleatório entre 0 e limite*
- *o limite é dobrado a cada colisão sucessiva até o número máximo de colisões. Se não conseguir transmitir aborta.*
- *retardo de transmissão pequeno no começo e grande depois, impedindo sobrecarga*
- *padrão IEEE 802.3: limite dobra até 10 tentativas, depois permanece inalterado até no máximo 16 tentativas*